

ASMO

Circuit Bent Vtech Little Smart Tiny Touch Phone

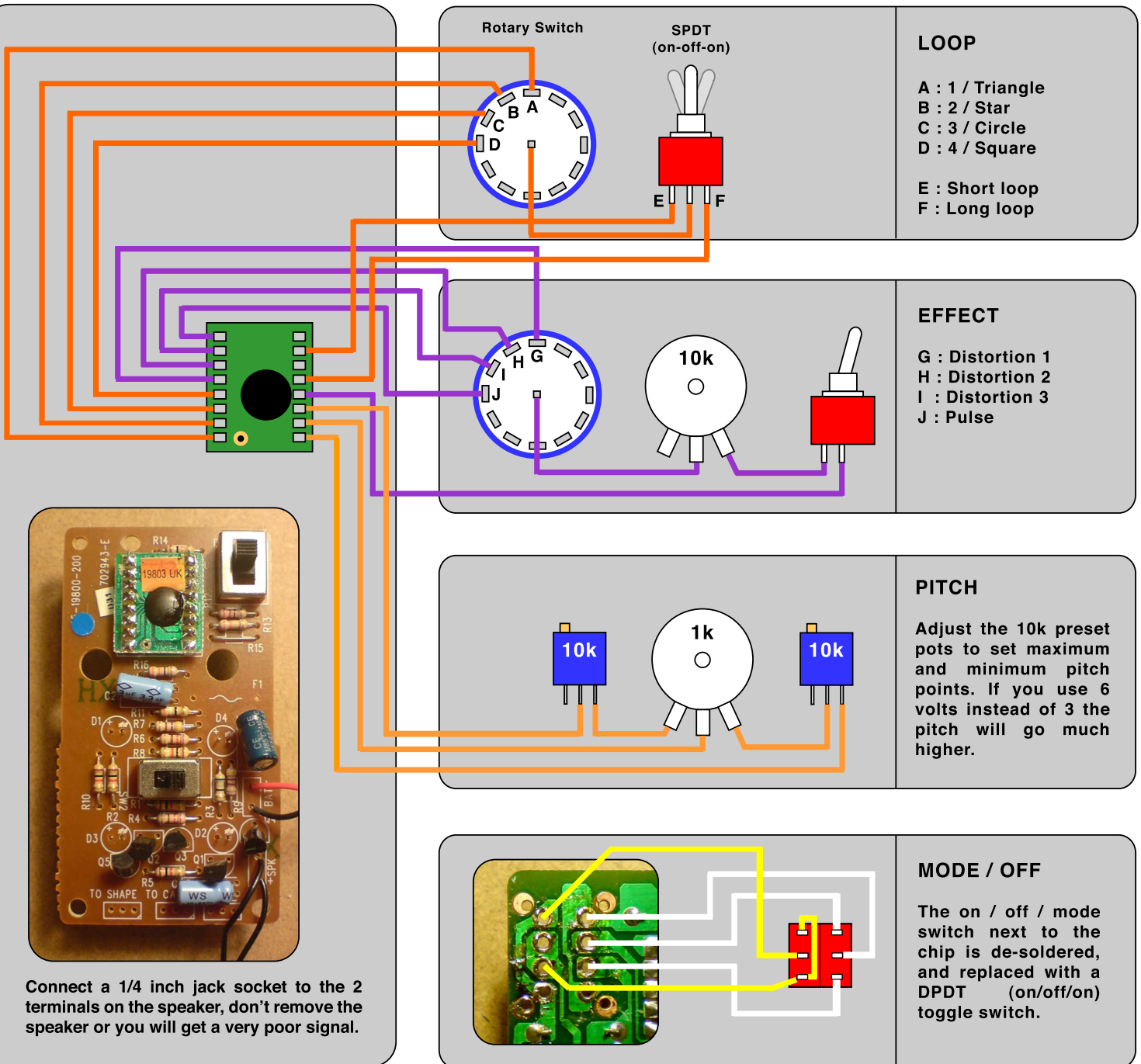

I have only shown the minimum required to achieve all the bends, use of rotary switches keeps the wiring simpler but you could also use separate toggle switches, I also added momentary push buttons to the audio out and effect, you can also double up the effect section to use multiple effects.

In addition you could add a simple 555 LFO circuit, connect the pulse out to the center lug on the pitch pot. Peter Edwards' Speak and Spell LFO works very well (see casperelectronics.com), you will need to omit the 10k resistor at the point marked 'C' on his LFO schematic.

youtube.com/asmovision
myspace.com/asmomusik
bathysphere.co.uk